



Q2 2018

INTERIM REPORT

April 1 - June 30, 2018

 FLEXQUBE®

Transforming intralogistics

THIS IS FLEXQUBE

FlexQube is a global provider of flexible and robust industrial carts for material handling. The Group was founded in 2010 and in a short period of time has secured a large number of prominent companies as customers.

Standardized interfaces and modular building blocks allow for a unique, efficient and scalable design process where customers have access to customized cart solutions.

Material presentation and transport, with the help of configurable carts, streamline material flows, reduce accidents with forklifts and improve ergonomics and the work environment.

Currently, FlexQube's sales organization focuses on Europe and North America with manufacturing in Sweden for the European market and in Georgia, USA for the North American market.

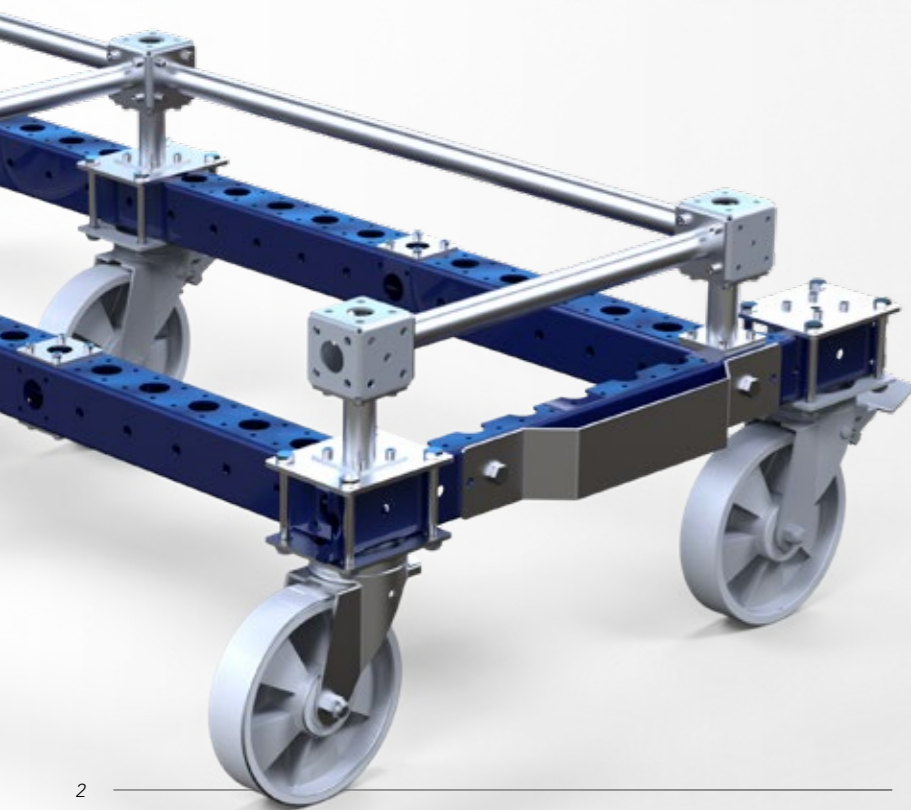

If you loved to play with Lego® or Meccano® as a child, and as an adult strive for effective internal logistics, you will love this.

Per Augustsson
Inventor, co-founder and Technical Manager at FlexQube®

- 2010
FlexQube is started by Anders, Christian and Per in December 2010
- 2011
The patent is granted
- 2012
Sales launch
- 2013
FlexQube Inc. is launched
- 2014
"Made in USA"
- 2015/16
Ranked on the "33-listan" (top 33 most innovative companies in Sweden) two years in a row and new logotype
- 2017
Sales to 22 countries and listing on the Nasdaq First North



- 2020
#1 Global supplier of material handling carts

INTERIM REPORT

April 1 - June 30, 2018

- Order intake increased by 200 percent to 22.1 MSEK (Million Swedish kronor) (7.4).
- Net sales increased by 132 percent to 16.8 MSEK (7.3). Adjusted for currency rates between comparative periods, net sales increased by 134 percent.
- Operating profit (EBIT) amounted to -3.1 MSEK (-0.4).
- Profit before taxes amounted to -3.1 MSEK (-0.4).
- Cash flow amounted to 0.3 MSEK (0.6), of which -0.1 MSEK (0.7) came from operating activities, -1.3 MSEK (0.0) from investment activities and 1.7 MSEK (-0, 3) from financing activities.
- Cash and cash equivalents amounted to 20.6 MSEK (1.1) at the end of the period.
- The company has conducted an intensive trade show quarter by attending three trade shows in Europe and North America. The company carried out its biggest campaign ever at MODEX in Atlanta in early April with very successful results. In addition to MODEX, the company participated in Intra-Logistics Latin America in Mexico City, Mexico, and in Intra-Logistica Italia in Milan, Italy.
- The product development project "FlexQube 4.0" is moving forward and the company presented a "connected" remote-controlled cart for the first time at MODEX. There was a great deal of interest and development work further intensified during the quarter, where several milestones in the development project were passed.
- FlexQube Inc., USA, employed Cherie Dimmerling as Key Account Manager for initially five multinational industrial companies, Shawn Lynch as Sales Manager Southeast and Julio Humberto Lopez Inurreta and Juan Pablo Heredia Lavín as assemblers in Mexico.
- At the end of June, FlexQube Europe AB began roll forming production, which will mean increased capacity and reduced costs for the company's most important component "FlexBeam™". The plant will initially also produce for overseas markets. The company estimates that the effects will be visible in the fourth quarter.
- In addition to several other prestigious orders, FlexQube Inc. received its single second largest order from Brose Fahrzeugteile in Mexico, which amounted to approximately 6.1 MSEK.
- A scaling up project on the supply chain and manufacturing in North America was launched at the end of the quarter with the aim of increasing supply capacity without linear cost increases. The company estimates that the effect of this will come during the fourth quarter.
- The company broke the record for RFQs ("Request For Quote" - meaning project flow from customers) over a 3-month period.

Order intake increase

Sales growth

+132% +200%



FlexQube at Intra-Logistica Italia in Milan, Italy

January 1 - June 30, 2018

- Order intake increased by 154 percent to 36.2 MSEK (Million Swedish Kronor) (14.3).
- Net sales increased by 104 percent to 33.2 MSEK (16.3). Adjusted for the impact of currency rates between comparative periods, net sales increased by 111 percent.
- Operating profit (EBIT) amounted to -4.4 MSEK (-1.5).
- Profit before taxes amounted to -4.5 MSEK (-1.6).
- Cash flow amounted to -13.5 MSEK (1.0), of which -13.2 MSEK (1.3) came from operating activities, -2.8 MSEK (0.0) from investment activities and 2.5 MSEK (-0, 3) from financing activities.
- Cash and cash equivalents amounted to 20.6 MSEK (1.1) at the end of the period.

Events after the second quarter

- FlexQube Europe AB has hired Elin Leander as accountant and HR manager. Elin comes to us from management consultant firm Triathlon Group.
- Further tests have been carried out regarding "FlexQube 4.0" with positive outcomes.
- FlexQube Inc. has reached a new agreement with its main supplier in North America, which will reduce risk and cost as well as allowing for greater predictability of these costs in relation to the company's sales.



THE CEO HAS THE FLOOR

STRONG ORDER INTAKE AND NEW MARKETING CAMPAIGNS

During the second quarter of the year, our order intake continued in a very positive direction, where total order intake grew by more than 200 percent. We still see a favorable development in North America with a great deal of recurring customers, not only at the company level, but also at the personal level, when people we worked with contacted us again after moving to a new employer. Our digital marketing and presence at industry fairs contribute a great deal of value, but the most effective marketing for FlexQube is that existing customers are satisfied and speak well of us.

Sales for the quarter landed at almost 17 MSEK, which means a growth of 132 percent compared to the corresponding quarter of 2017. The challenges in the supply chain reflected in the first quarter report are something we are still working continuously with, in order to keep delivery times for customers down. In early July, we launched our new manufacturing process in Falkenberg, roll forming, of our most important component, FlexBeam™. With this method we will be able to achieve reduced FlexBeam™ production costs and shorter lead times, resulting in both increased competitiveness and improved margins. It is estimated that it will take until the fourth quarter until we see an impact on the gross margin. In connection with the stock exchange listing in December 2017, we presented the intended allocation of the funds we received, with the largest item being sales and marketing efforts. Here we have had a good start with new recruitment of sales people, but also with participation in five trade shows in the first half of 2018. We continue to actively seek sales resources in different markets, but it should be pointed out that marketing costs will fall in the second half of this year.

For a newly recruited sales person, it takes about 6-18 months to build customer relationships and customer projects. Having said that, it is worth remembering that the order intake during the first half of this year is attributable to sales efforts made prior to the listing at NASDAQ. Several of the larger businesses we close may have been processed by sales resources for up to three years.

Our absolute focus lies in growth, expanding the customer base and preparing the organization for larger volumes. During the first half of the year,

marketing costs have also been higher as previously mentioned (as most trade shows are in the spring). Investing in tools for our new manufacturing process is part of a larger gross margin project that began during the quarter. Here we work with profitability improvement measures in different areas and the money released from such projects will be additional fuel for profitable market growth. The negative result for the first half of the year is in line with our internal growth plan, balanced with a controlled cost level.

Our absolute focus lies in growth, expanding the customer base and preparing the organization for larger volumes.

There is great opportunity to significantly increase market share in our fragmented market and in addition to focusing on a growing customer base, we are working hard to increase our presence at more factories in the global companies we have come across. During the quarter we received follow-up orders from, among others, the Volvo Car Group, Eberspächer, several major orders from Vestas, and from Siemens in both the US and Europe. Electric bus manufacturer Proterra, which we have partnered with since spring 2017, continues to place orders

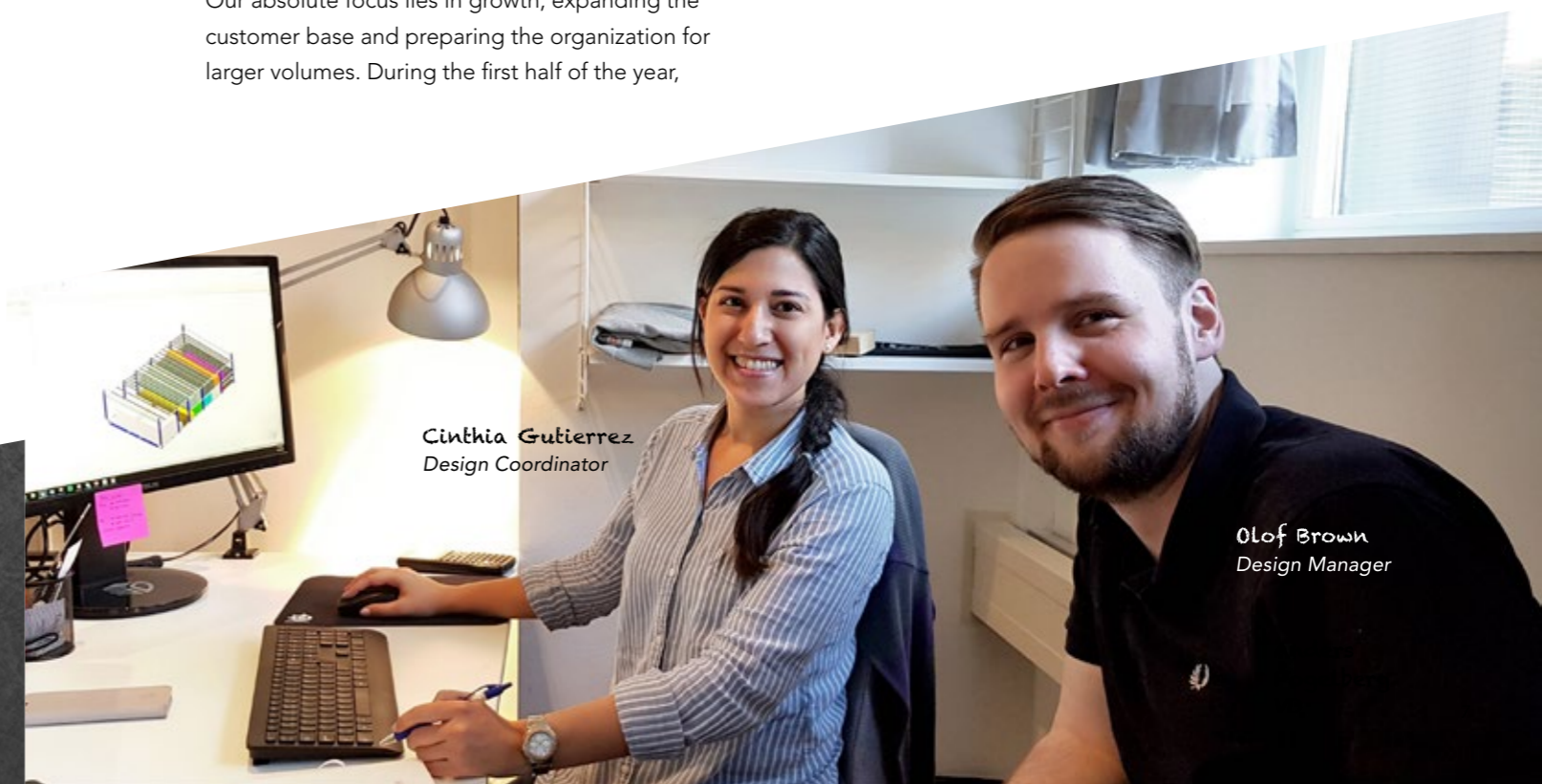

Cynthia Gutierrez
Design Coordinator

Olof Brown
Design Manager

on both new and existing solutions almost weekly. During the second quarter, several new employees began to work with us. Three in sales, one in the supply chain and one in design and development. We are very pleased with the development on the staff side and we continue, as mentioned previously, to be active in building a larger team.

Our technology development in autonomous and robotic carts is rapidly moving forward and in April we exhibited our first prototype of a remote-controlled electric cart at a trade fair in the United States. The interest is strong for this type of solution, which reduces the threshold for introducing automated carts in factories. We have discussions with several major car manufacturers about pilot projects in the fall in both Europe and the United States.

“We will do everything we can to take advantage of the opportunities we have to increase our market share, even though hard work is always required.”

Although automotive industry carts account for a large part of our order intake, we are also growing steadily in other segments. During the second quarter, we saw a significant part of order intake from airplane and train manufacturers, distribution warehouses and the wind power industry. The number of components being managed increases in every industry and things are changing continuously. Our unique ability to help customers develop cart solutions in a fast and easy way is an important competitive advantage for us. Customers make use of the flexibility of the concept to optimize the carts for new conditions even, in some cases, before they have been used for the first time.

During the first half of the year, we began our campaign in the largest European market, Germany. FlexQube GmbH was launched and we hired our first German sales person based in Munich. Germany has previously proved to be a demanding market to break into. Companies are highly technology-focused and often choose established suppliers rather than startup companies such as FlexQube. There is however a great deal of interest in our concept, but it takes time before a new company can be registered in the supplier databases and projects can begin. We are executing a clear plan that shortly will lead to Germany becoming our largest European market. Sales and marketing efforts will make up a significant part of this plan, although we are prepared to be patient as we understand that it will take some time to see results. I compare this to the United States where we launched our efforts in 2014 and now have steady sales growth. Our cooperation with STILL GmbH involving carts for Liftrunner is also an important part of this and we have a good relationship with LR Intralogistik, the company behind the popular Liftrunner trains.

I am very proud that we can deliver to large and prominent companies, something that is possible thanks to the amazing work of our staff. Our customer focus combined with our extensive knowledge of materials management and a unique concept, allows us to solve problems for our customers and create long-term loyalty to FlexQube. We will do everything we can to take advantage of the opportunities we have to increase our market share, even though hard work is always required. As Thomas Edison said, “Opportunity is missed by most people because it is dressed in overalls and looks like work”.



Anders Fogelberg
CEO, FlexQube AB



Jan Brettmann
Sales Manager
DACH

Andy Legut
Sales Manager
Midwest, USA

Hector Flores
Sales Manager
Mexico

DEVELOPMENT DURING THE SECOND QUARTER

April 1 - June 30, 2018



Numerical data provided in brackets in this interim report refers to the comparison with the interim period April- June 2017 or the balance sheet date 6/30/2017. FlexQube's accounting currency is Swedish kronor (SEK).

ORDER INTAKE, REVENUES AND RESULT

The Group's order intake during the second quarter of the year amounted to 22.1 MSEK (7.4), an increase of 200 percent compared to the same quarter last year. The Group is still young and there may therefore be strong fluctuations between the quarters. The Group evaluates the accumulated order intake over several periods as more significant than individual quarters.

Net sales for the quarter amounted to 16.8 MSEK (7.3), an increase of 132 percent compared with the previous year. Adjusted for currency rates between comparative periods, net sales increased by 134 percent. Total revenue increased by 140 percent and amounted to 17.6 MSEK (7.3) at the end of the period. The increase in sales is mainly attributable to growth in the North American market.

The cost of commodities which include commodity purchases and related expenses for distribution, such as freight and packaging, amounted to 10.0 MSEK (4.2) and is due to the increased sales volume in general.

Other external expenses amounted to 6.9 MSEK (2.5).

The increase in these costs has been according to planned expansion and mainly relates to:

- Increased marketing and sales activities including trade shows during the current interim period in the United States, Mexico and Italy, an increase in demos sent to clients, and overall increased sales travel in Europe and North America, as well as the production of new marketing and printed catalog materials,
- Increased distribution management costs, primarily in North America,
- Increased expenses for Group staff in the form of board fees and board management tools, where a new member of the board has been added during the current quarter,
- Increased administrative costs for accounting and back office, as well as the purchase of new accounts and licenses for administrative IT tools due to increased staff and sales volume,

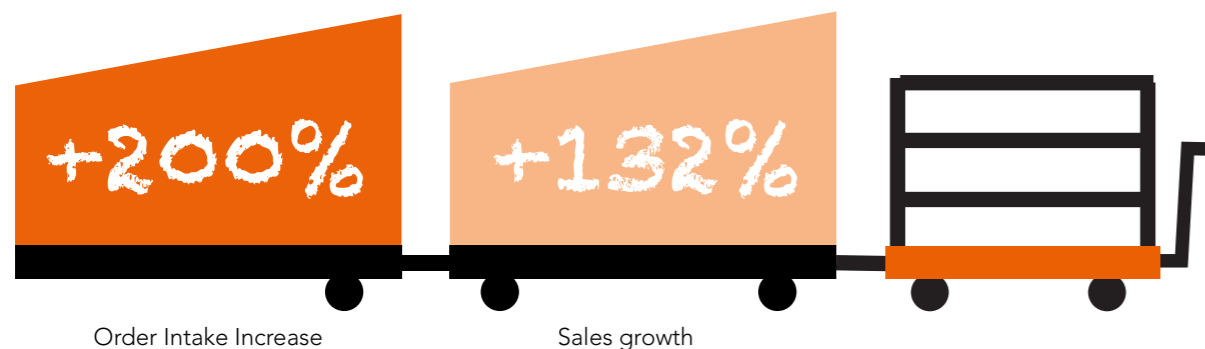

- Increased costs for the design department as a result of sales development and design development projects,
- NASDAQ management costs, and
- Operating costs for the German subsidiary, FlexQube GmbH.

Despite the aforementioned increase in external costs between the comparison periods, these costs are only 17 percent higher in relation to sales between the periods.

Personnel costs amounted to 3.6 MSEK (0.9). The increase between the periods relates to the planned expansion, which includes:

- Increased personnel in North America and Europe as well as related recruitment costs,
- The company has a retirement plan for all employees since January 1st, 2018,
- The sales staff's commission costs have followed the increased sales trend in the company, and
- Management has received a market compensation in comparison with the previous year.

Operating profit amounted to -3.1 MSEK (-0.4). Profit before taxes amounted to -3.1 MSEK (-0.4) and profit after taxes amounted to -3.1 MSEK (-0.6).

For the second quarter, tax on earnings for the period amounted to 0.0 MSEK (0.1) and this was due to the negative earnings for the period. Deferred tax claims on carry-backs have not been taken into account.

CASH FLOW

Cash flow for the period amounted to 0.3 MSEK (0.6), of which

- Cash flow from ongoing operating activities amounted to -0.1 MSEK (0.7), primarily driven by the change in operating receivables and inventories,

combined with a decrease in earnings compared to the previous year. The change in operating receivables is attributable to the fact that the company chose not to finance accounts receivable through the Group's financial structure with credit institutions related to invoice sales, due to its own acceptable liquidity. The change in operating liabilities and inventories is due to increased accounts payable and inventory levels, as a result of the company's sales growth.

- Cash flow from investing activities amounted to SEK -1.3 MSEK (0.0), most of which relates to investments in commercial vehicles that have been included in the Group's consolidated balance sheet as a result of financial leasing, investments for property, plant and equipment linked to the production and further development of the FlexQube concept, as well as investments of lesser value in intangible capital assets such as patents and trademarks.
- Cash flow from financing activities amounted to 1.7 MSEK (-0.1). The difference between comparison periods is attributable to the use of available overdraft facilities and the planned amortization of loans, in addition to an accrued liability item for financial leasing of approximately 0.4 MSEK.

DEPRECIATION, WRITE-DOWNS AND INVESTMENTS

Depreciation for the period amounted to 0.2 MSEK (0.1).

Investments during the period mainly concern tangible capital assets, partly office equipment, which together with development costs related to production improvement of the current concept and a development program that will complement FlexQubes mechanical building blocks with mechatronic components, amounted to 0.6 MSEK (0.0) and partly an asset of service vehicles, which amounted to 0.7 MSEK (0.0).

DEVELOPMENT DURING THE ACCUMULATED PERIOD

January 1 - June 30, 2018



Numerical data provided in brackets in this interim report refers to the comparison with the interim period January - June 2017 or the balance sheet date 6/30/2017. FlexQube's accounting currency is Swedish kronor (SEK).

ORDER INTAKE, REVENUES AND RESULT

The Group's order intake during the first quarter of the year amounted to 36.2 MSEK (14.3), an increase of 154 percent compared to the same quarter the previous year. The Group is still young and there may therefore be strong fluctuations between the quarters. The Group evaluates the accumulated order intake over several periods as more significant than individual quarters.

Net sales for the period amounted to 33.2 MSEK (16.3), an increase of 104 percent compared with the previous year. Adjusted for currency rates between comparative periods, net sales increased by 111 percent. Total revenue increased by 107 percent and amounted to 34.2 MSEK (16.6) at the end of the period. The increase in sales is mainly attributable to growth in the North American market.

The cost of commodities that includes commodity purchases and related expenses for distribution, such as freight and packaging, amounted to 20.3 MSEK (9.9) and is due to the increased sales volume in general.

Other external expenses amounted to 10.2 MSEK (5.7). The increase in these costs has been according to planned expansion and mainly relates to:

- Increased marketing and sales activities including trade shows during the current half-year in Germany, the Netherlands, the United States, Mexico and Italy,

increased overall sales travel in Europe and North America,

- Production of new marketing materials and printing of hard copy catalogs,
- Increased distribution management costs, primarily in North America,
- Increased expenses for Group staff in the form of board fees and board management tools, where a new member of the board has been added during the second quarter,
- Increased administrative costs for accounting and back office, as well as the purchase of new accounts and licenses for administrative IT tools due to increased staff and sales volume,
- Increased costs for the design department as a result of sales development and design development projects,
- NASDAQ management costs, and
- One-off start-up costs and ongoing operating costs for the German subsidiary, FlexQube GmbH.

Despite the aforementioned increase in external costs between the comparative periods, these costs have decreased by 13 percent in relation to sales between the periods.

Personnel costs amounted to 7.8 MSEK (1.7). The increase between the periods relates to the planned expansion, which includes:

- Increased personnel in North America and Europe as well as related recruitment costs,
- The company has introduced a pension plan for all employees,
- The sales staff's commission costs have followed the increased sales trend in the company, and
- Management has received a market compensation in comparison with the previous year.

Other operating expenses amounted to 0.0 MSEK (0.5). Fluctuations of this cost item are primarily driven by changes in the currency rate involving inter-company transactions.

Operating profit amounted to -4.4 MSEK (-1.5). Profit before taxes amounted to -4.5 MSEK (-1.6) and profit after taxes amounted to -4.5 MSEK (-1.7).

For the first six months of the year, tax on earnings for the period amounted to 0.0 MSEK (0.1) and this was due to the negative earnings for the period. Deferred tax claims on carry-backs have not been taken into account.

CASH FLOW

Cash flow for the period amounted to -13.5 MSEK (1.0), of which

- Cash flow from ongoing operating activities amounted to -13.2 MSEK (1.3), primarily driven by the change in operating receivables combined with changes in inventories, as well as a decrease in earnings compared to the previous year. The change in operating receivables is attributable to the fact that the company chose not to finance accounts receivable through the Group's financial structure with credit institutions related to invoice sales, due to its own

acceptable liquidity. The change in operating liabilities and inventories is due to increased accounts payable and inventory levels as a result of the company's sales growth.

- Cash flow from investing activities amounted to -2.8 MSEK (0.0), most of which relates to investments in service vehicles that have been included in the Group's consolidated balance sheet as a result of financial leasing and own direct ownership. Remaining investments relate to intangible capital assets such as patents and trademarks as well as investments in property, plant and equipment linked to the production and further development of FlexQube's concepts.
- Cash flow from financing activities amounted to 2.5 MSEK (-0.3). The difference between comparison periods is attributable to the use of available overdraft facilities and the planned amortization of loans, in addition to an accrued liability item for financial leasing of approximately 1.4 MSEK.

DEPRECIATION, WRITE-DOWNS AND INVESTMENTS

Depreciation for the period amounted to 0.3 MSEK (0.2).

Investments for the period include intangible capital assets in the form of patents and trademarks and amounted to 0.1 MSEK (0.0). Investments in property, plant and equipment partly involves office equipment, which together with development costs related to production improvement of the current concept and a development program that will complement FlexQubes mechanical building blocks with mechatronic components, amounted to 0.9 MSEK (0.0) and partly an asset of service vehicles, which amounted to 1.8 MSEK (0.0).

FINANCIAL POSITION

The Group's balance sheet as of June 30, 2018 with comparison period June 30, 2017

The company's total assets to June 30, 2018 amounted to 51.7 MSEK (10.4), of which:

Intangible capital assets amounted to 2.0 MSEK (1.7) and consists of expenses for development work on IT and software solutions for customers as well as patents and trademarks.

Property, plant and equipment amounted to 2.9 MSEK (0.3) at the end of the period, and consisted of office equipment and office inventory, development costs linked to production improvement of the current concept, as well as a development program to complement FlexQube's mechanical building blocks with mechatronic building components, and capital assets related to service vehicles that have been included in the Group's balance sheet as a result of financial leasing, along with a directly owned vehicle at FlexQube GmbH.

Financial capital assets in the form of leasehold positions amounted to 0.2 MSEK (0.2) at the end of the period.

Current assets amounted to 46.6 MSEK (8.2) as of June 30, 2018, of which inventories amounted to 13.1 MSEK (4.8), accounts receivable including earned but un invoiced income amounted to 9.0 MSEK (1.4) and cash and cash equivalents amounted to 20.6 MSEK (1.1). The increase in cash and cash equivalents is

attributable to the issue of new shares in December 2017, in connection with the company's public offering. Other short-term receivables, tax receivables and prepaid expenses and accrued income amounted to 3.9 MSEK (0.8), where the difference between the periods is attributable to prepaid accounts payable and receivables relating to value added tax.

At the end of the period, equity amounted to 31.9 MSEK (-1.2). The change in equity is also attributable to the issue of new shares in December 2017 as well as in addition to received shareholders' contributions.

Long-term liabilities amounted to 3.0 MSEK (4.0), this change was due to the amortization of long-term loans in 2017, and accrued liability items relating to finance leases by approximately 1.4 MSEK.

Short-term liabilities amounted to 16.8 MSEK (7.6), mainly consisting of accounts payables combined with accrued costs, which relate to the company's increased sales volume. 1.5 MSEK (1.8) of the total overdraft limit of 2.3 MSEK for the respective comparative period was utilized at the end of the period.



CUSTOMER BASE

FlexQube's customers are found in different industry segments and regions. To June 30, 2018 FlexQube has a customer base of approximately 315 customers in 23 different countries. The majority of these 315

customers are the result of the last two to three years of work and the Group expects all customer accounts to develop even more positively in the coming years. Below are the segments that FlexQube operates in:

-  Manufacturing of commercial vehicles such as trucks, buses and trains
-  Manufacturing of cars
-  Tier 1s to the automobile industry
-  Manufacturing of construction and industrial machinery
-  Manufacturing of wind turbines and other energy related products
-  Manufacturing of defense equipment
-  Manufacturing of appliances and electronics
-  Storage and distribution of goods
-  Manufacturing of medical equipment

ORDER INTAKE

Order intake increased by 200 percent during the second quarter compared with the same period in 2017, and amounted to approximately 22.1 MSEK (7.4). For the third quarter in a row, we show an increase in order intake of over 100 percent, and this is the result of the hard work carried out, especially since January 1, 2017. For the first six months of 2018, order intake growth was around 154% despite the new sales organization not yet having contributed to growth.

customer if implemented broadly, but where implementation is to a certain extent governed by the projects being implemented. Historically, FlexQube has not seen a customer stop buying products, but rather that their need consistently increases over time. At the same time, said need is governed by the other projects in progress with the customer, which may vary from year to year.

Order intake is one of FlexQube's most important metrics and something that will be communicated to the market to the extent that the Group considers a single order to be of sufficient importance for communication. Even though there is an existing customer base with very prominent customers and great potential, FlexQube is still young, and large continuous sales are not self-evident, even if they continue to grow day by day. FlexQube offers a concept where the benefits will be greatest for the

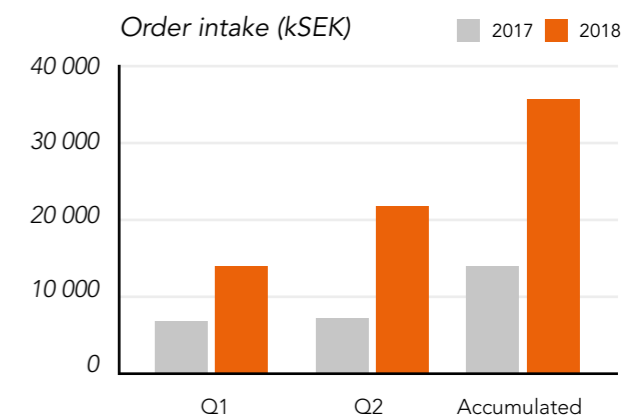

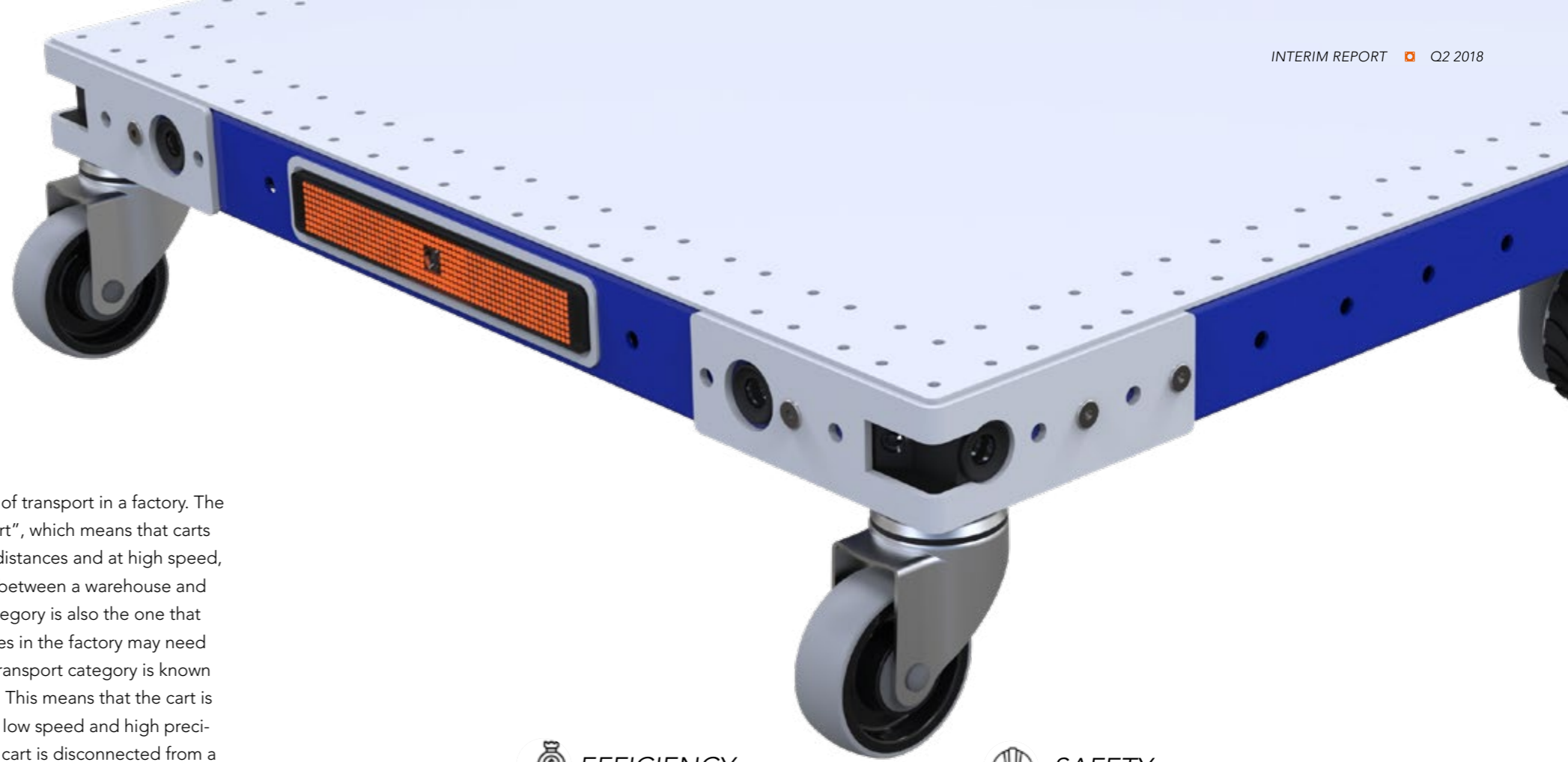

FLEXQUBE 4.0

Plug & Play Automation

FlexQube 4.0 is an innovative concept for automating transports in factories and warehouses. The concept offers FlexQube's customers the opportunity to introduce automation with an ease that has never been possible before.

The demands on the future's internal logistics are extreme. The number of items to be handled is increasing rapidly and they must be delivered with increasing frequency to the production lines. An increasing number of activities at a factory are logistics-related, which makes it even more interesting to evaluate the possibility of automation. Both from a perspective of wanting save time, but also from an ergonomic perspective to remove heavy moments from the operators.

Unfortunately, automation in factories has historically been, and still is, complex requiring expensive installations. The ambition to automate 100% of a logistics process involves an overly high cost with regards to the ability to adapt the process to new conditions such as new products, items or logistics routes in the factory. Changes become expensive, complex and limit the ability to make the necessary efficiency improvements.

FlexQube's vision is that human beings will still play a decisive role in future factories. People are the most flexible machines available, and if this can be combined with the automation of time-consuming activities, long-term, scalable and flexible automation can be achieved. If 50% of logistics activities are automated, this implies very big savings, while providing the ability to maintain a high level of flexibility.

We have studied our customers' logistics processes to understand where the greatest need for automation exists.

There are two categories of transport in a factory. The first is "long-haul transport", which means that carts are transported for long distances and at high speed, eg. movement of pallets between a warehouse and an assembly line. This category is also the one that requires flexibility as routes in the factory may need to change. The second transport category is known as "short-haul transport". This means that the cart is moved short distances at low speed and high precision, for example when a cart is disconnected from a train and manually placed 2 meters further down the assembly line.

We have studied our customers' logistics processes to understand where the greatest need for automation exists

Short-haul transport is also associated with physically demanding work, as opposed to long-haul transport, which in most cases means that the operator drives a vehicle, such as a tow tractor pulling a train with wagons.

From an automation perspective, automating short-haul transport would be of great value, which is a clear strategy in the FlexQube 4.0 concept. For long-haul transport, operators will still be involved to provide a simple, flexible and scalable automation.

Per Augustsson
CTO FlexQube Group

EFFICIENCY

Short-haul transfers, which today have a high level of manual operations, are 100% automated through the automatic parking feature. Long-haul transfers are carried out by platooning, where long trains of carts are transported together, and where the first cart is controlled by an operator via remote control from the control tower and the remaining carts copy the first cart.

SIMPLICITY

Plug & Play is the keyword. A Wi-Fi network is the only infrastructure needed, which allows automated carts to be easily and quickly implemented in existing factories.

FLEXIBILITY

FlexQube 4.0 is based on FlexQube's standardized modular system and can be installed on both existing and new carts. This allows for automated trolleys of different sizes and functions. Cart routes and parking positions can be changed freely when needed.

SAFETY

FlexQube 4.0 increases safety and reduces the number of accidents significantly, as sensors and cameras that detect both people and objects are installed on the carts. Automation also means that fewer people will move in truck lanes which reduces the risk of personal injury.

ERGONOMICS

Given that the FlexQube 4.0 concept means carts are motorized, all of the moments that are currently ergonomically heavy for operators will be eliminated, allowing for increased transport frequency and load weight.

FACTORY FLOOR

Platooning allows for truck aisles to be made significantly narrower than required for traditional train solutions. The released production area can be used to increase the factory's capacity without expanding the building.

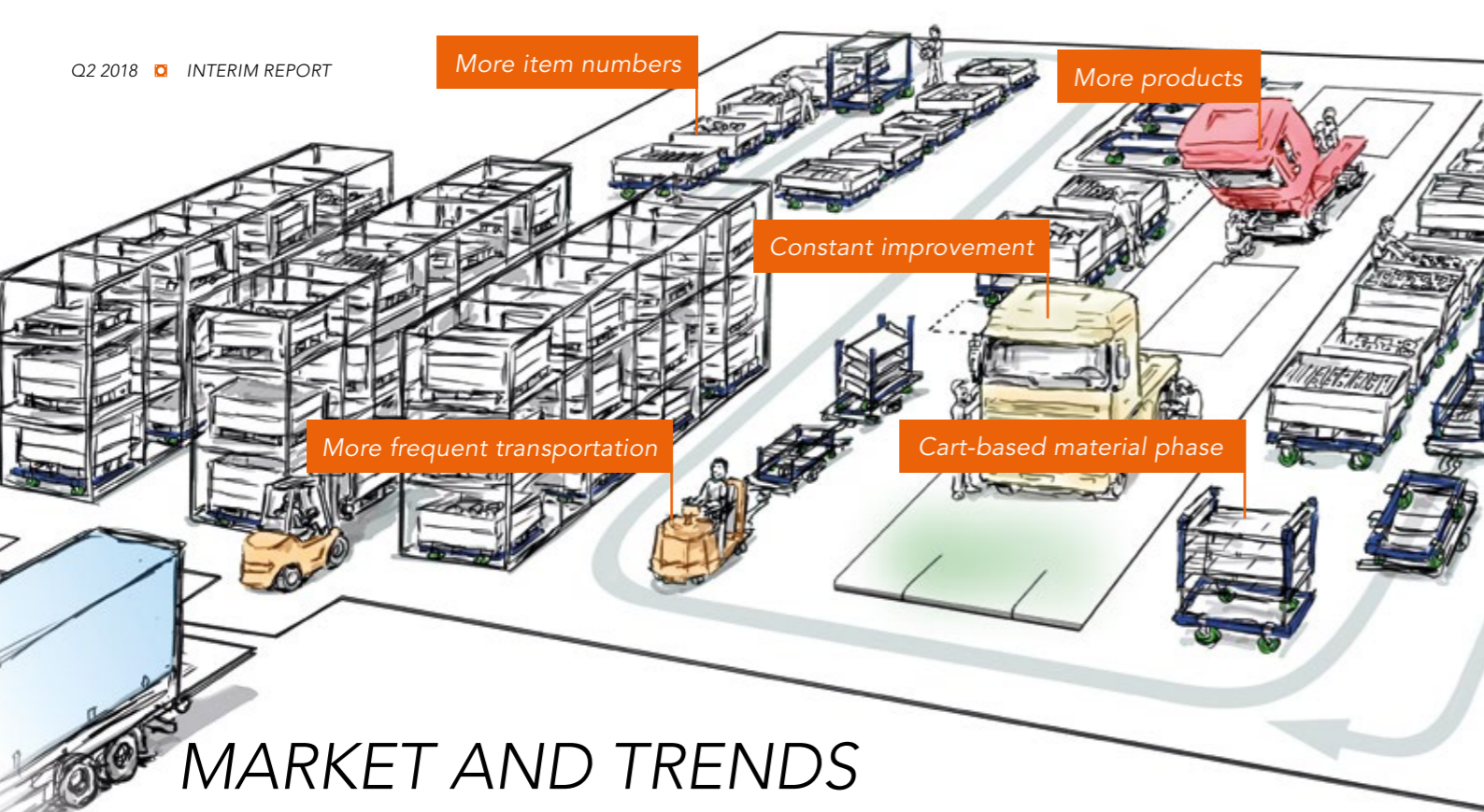

MARKET AND TRENDS

FlexQube is a global supplier of modular and robust industrial carts for material handling. The Group was founded in 2010 and ever since then has had the ambition to create a brand new market. Today, the Group has a sales organization that focuses on Europe and North America. Manufacturing takes place in Sweden for the European market and outside Atlanta in the US for the North American and Mexican markets.

The industries and segments that FlexQube operates within undergo major challenges in the field of material handling, where today's consumers expect more and more products and variants to choose from. The paradigm shift, called "mass customization", began in the late 1980s and has since developed into a situation where the number of products and variants offered has increased significantly.

RISK AND UNCERTAINTIES

FlexQube is an internationally active company, which is exposed to a number of market and financial risks. Identified risks are monitored continuously, where measures to reduce the risks and their effects are taken if necessary.

Examples of financial risks are market, liquidity and credit risks. Market risks consist mainly of currency risk. It is the Board of Directors of FlexQube, which is

The mass customization phenomenon drives a huge need for the products offered by FlexQube, such as the need to switch from truck-based material handling to cart-based material handling, as demands for safe and frequent transport increase. In addition to this paradigm shift, global uncertainty, rapid changes in volume and mix, as well as rapid technology development, add greater demands on flexibility and the ability to re-configure the carts.

FlexQube's goal is to help its customers improve their internal logistics and achieve this by creating unique material carts with modular building blocks, an innovative design process, and a high level of internal logistics skills.

ultimately responsible for managing and monitoring the Group's financial risks. Currency and liquidity risks represent the most significant financial risks, while interest, financing and credit risks can be considered lower risks.

Currency risk is due to the fact that some of the Group's revenues are in EUR for the European entity, while operating expenses are mainly in SEK.

The US entity has local manufacturing and supply chain in the US and only limited purchases are made from markets other than the United States. Consequently, currency risk is limited to the US entity, excluding any potential in-house transactions.

The liquidity risk is primarily due to the fact that the Group's major customers require long payment periods and that the Group is in an expansion phase. The Group is actively working to reduce these risks, where existing global financing agreements ensure a satisfactory cash flow. Liquidity risk is managed on an ongoing basis in cooperation with the Group's lenders and other financial collaborators-partners.

CURRENCY

FlexQube's largest markets are Europe and North America. Given that the Group's reporting currency is in SEK, the Group's earnings are affected by currency translation effects on receivables and / or liabilities in USD and EUR.

STAFF

The number of employees at FlexQube reflects the scalable business model that the Group actively works with, in part to exploit economies of scale in the longer term, but also because of a somewhat limited costs in the short term.

The number of employees as of June 30, 2018 was 19 (10), of whom 3 were women (1). The average number of employees during the interim period April to June 2018 was 17 (10), of whom 3 were women (1).

Although the number of employees in the company is relatively few, the company still has a wide range of expertise in relevant areas, stemming from the background, education and experience of its employees. In addition, if necessary, the company will hire staff to gain the necessary skills and to a large extent cooperate with the company's subcontractors. It can thus be pointed out that, within the company's business model, the company has over 30-40 employees based with suppliers and external consultants.



FLEXQUBE-SHARES

FlexQube's share capital amounted to 0.63 MSEK on Saturday, June 30, 2018. The number of shares amounted to 6,333,333 with equal rights, corresponding to a quota value of 0.1 SEK.

The company's stock is listed on the Nasdaq Stockholm First North under the FLEXQ symbol since December 14, 2017. FlexQube had a sales volume of 256 928 shares during the period between April 1 and June 30, 2018. This resulted in an average sales volume of 4 282 shares per trading day worth 160,867 SEK. The average price of the share during the period was approximately 37.6 SEK.

FlexQube had a sales volume of 619,917 shares during the accumulated period between January 1 and June 30, 2018. This resulted in an average sales volume of 5,040 shares per trading day worth 190,068 SEK. The average price of the share during the period was approximately 37.7 SEK.

The last closing at the end of the period was 37.6 SEK, meaning an increase of approximately 25.3% from the subscription price associated with the public listing on December 14, 2017.

ACCOUNTING PRINCIPLES

The current interim report is prepared according to ÅRL and the Swedish Accounting Board's BFAR 2012: 1 Annual Report and Consolidated Financial Statements (K3).

Below are the most important accounting principles described.

CONSOLIDATED FINANCIAL STATEMENTS

Companies in which FlexQube holds the majority of votes at the Annual General Meeting are classified as subsidiaries and consolidated in the consolidated financial statements. Subsidiaries are included in the consolidated financial statements from the date on which the controlling influence is transferred to the Group. They are excluded from the consolidated financial statements from the date on which the controlling influence ceases.

The consolidated financial statements have been prepared in accordance with the acquisition method. The acquisition date is the date on which the controlling influence is obtained. Identifiable assets and liabilities are initially valued at fair value on the acquisition date. Goodwill / Negative Goodwill is the difference between the acquired identifiable net assets at the acquisition date and the acquisition value including the value of the minority interest, and is initially valued at the acquisition value. The Group has never reported any Goodwill. Negative Goodwill has arisen during an acquisition and is distributed in full before the beginning of 2015.

TRANSACTIONS BETWEEN GROUP COMPANIES ARE ELIMINATED IN THEIR ENTIRETY

Subsidiaries in other countries prepare their annual accounts in foreign currency. Upon consolidation, the items in these subsidiaries' balance sheets and profit bills at the closing date, with respect to the current rate for the day the respective business event took place, are calculated.

The exchange rate differences arising from the calculation of the balance sheet for foreign subsidiaries are reported in cumulative exchange rate differences in the Group's equity.

FOREIGN CURRENCY

Monetary assets and liabilities denominated in foreign currencies are valued at the current rate of the closing day. Transactions in foreign currency are calculated at the transaction date exchange rate.

REVENUE

Sales of goods are reported when significant risks and benefits are transferred from the seller to the buyer in accordance with the terms of sale. Sales are reported after deduction of VAT and discounts. Sales of services are reported when the service in question has been carried out under the agreed terms.

LEASE AGREEMENT

Leasing agreements which mean that the economic risks and benefits of owning an asset are essentially transferred from the lessor to the lessee and are classified in the consolidated financial statements as finance leases. Financial leases entail that rights and obligations are reported as assets and liabilities in the balance sheet. The asset and liability is initially valued at the least of the asset's fair value and the present value of the minimum lease payments. Expenses directly attributable to the lease are added to the value of the asset. Leasing fees are allocated on interest and amortization according to the effective interest rate method. Variable fees are recognized as an expense in the period they arise. The leased asset is depreciated on a straight-line basis over the estimated service life.

Leases where the economic benefits and risks that are attributable to the leasehold item remain in essence with the lessor, and are classified as operational leasing. Payments, including a first increased rental, under these agreements are reported as a linear cost over the lease period.

EMPLOYEE BENEFITS (SHORT-TERM BENEFITS)

Short-term benefits in the Group consist of salary, social security contributions, paid holiday, paid sick leave, healthcare and bonuses. Short-term benefits are reported as an expense and a liability when there is a legal or informal obligation to pay a compensation.

COMPENSATION AFTER ENDED EMPLOYMENT

The Group holds only defined contribution plans.

In defined contribution plans, the company pays fixed fees to another company and has no legal or informal obligation to pay anything further even if the other company can not fulfill its commitment. The Group's income is charged for expenses as employees' pensionable services are performed.

INCOME TAX

Current taxes are valued based on the tax rates and tax rules applicable on the balance sheet date. Deferred taxes are valued based on the tax rates and tax rules that are determined prior to the balance sheet date.

INTANGIBLE ASSETS

Intangible fixed assets are reported at cost less accumulated amortization and impairment losses. In terms of consolidated financial statements, the activation model for internally generated intangible assets applies.

Depreciation is carried out linearly over the estimated useful life. The amortization period for internally generated intangible capital assets amounts to five and ten years respectively.

TANGIBLE CAPITAL ASSETS

Tangible fixed assets are reported to acquisition value less depreciation. The acquisition value includes

expenses directly attributable to the acquisition of the asset. Expenses for ongoing repairs and maintenance are reported as expenses. Capital gains and losses on disposal of capital assets are reported as other operating income and other operating expenses respectively.

The following depreciation periods are applied:
Inventories, 5 years.
Cars, 3 years.

FINANCIAL INSTRUMENTS

Financial instruments are reported in accordance with the rules in K3 chapter 11, which means that valuation is based on cost.

Financial instruments recognized in the balance sheet include accounts receivable and other receivables, accounts payables and loan liabilities. The instruments are reported in the balance sheet when FlexQube becomes a party to the instrument's contractual terms. Financial assets are derecognized when the right to receive cash flows from the instrument has expired or been transferred and the Group has transferred virtually all risks and benefits associated with ownership.

Financial liabilities are derecognized when liabilities have been canceled or otherwise terminated.

INVENTORIES

Inventories are valued at the lowest of the acquisition value and net realizable value. The acquisition value is determined using the first-in, first-out method (FIFO).

CASH FLOW STATEMENT

The cash flow analysis is prepared according to the indirect method. The reported cash flow includes only transactions that have resulted in payments. The company classifies cash as liquid capital.



ABOUT THE PARENT COMPANY

FlexQube AB (publ) in Gothenburg with organization number 556905-3944 is the Group's Parent Company. In connection with the company's public offering, the Parent Company has established a management function for the Group, within the framework of corporate management and governance.

All other business-related transactions that do not concern Group management, with external and / or intra-Group parties, are primarily traded by the subsidiaries, with the Parent Company's development follows the development of the Group in general.

PARENT COMPANY'S ACCOUNTING PRINCIPLES

The same accounting and valuation principles apply in the Parent Company as in the Group, except in the cases listed below:

STOCKS AND SHARES IN SUBSIDIARIES

Shares and participation shares in subsidiaries are reported at cost minus any impairment losses. The acquisition value includes the purchase price paid for the shares as well as acquisition costs. Any capital contributions and Group contributions are added to the acquisition value when they are submitted. Dividends from subsidiaries are reported as income.

EQUITY

Equity is divided into restricted and unrestricted equity, in accordance with the Annual Accounts Act.

SIGNATURES

The Board of Directors and the Managing Director ensure that the interim report gives a true and fair view of the Parent Company and the Group's operations, position and results, and describes significant risks and uncertainties that the Parent Company and the companies included in the Group face.

Gothenburg, August 10, 2018

Ulf Ivarsson
Chairman of the Board

Anders Ströby
Member of the Board

Christian Thiel
Member of the Board

Per Augustsson
Member of the Board

Kristina Ljunggren
Member of the Board

Anders Fogelberg
CEO



GROUP'S KPIs

Earnings	Unit	Second quarter		6 months		Whole year
		2018 Apr-Jun	2017 Apr-Jun	2018 Jan-Jun	2017 Jan-Jun	2017
Order intake*	kSEK	22,094	7,353	36,249	14,259	37,232
Net Sales	kSEK	16,844	7,257	33,224	16,270	29,004
Group's Sales Growth**	%	132%	353%	104%	144%	51%
Operating profit before depreciation (EBITDA)	kSEK	-2,897	-298	-4,077	-1,298	-2,417
Operating profit (EBIT)	kSEK	-3,079	-387	-4,420	-1,475	-2,848
Operating margin	%	-18%	-5%	-13%	-9%	-10%
Earnings before taxes	kSEK	-3,123	-423	-4,518	-1,561	-3,050
Profit margin	%	-19%	-6%	-14%	-10%	-11%
Earnings per share before and after dilution***	SEK	-0,5	-0,1	-0,7	-0,3	-0,5
FINANCIAL POSITION						
Net debt including shareholder loans	kSEK	-26,833	3,460	-26,833	3,460	-33,451
Operating capital	kSEK	29,875	570	29,875	570	35,266
Balance liquidity	%	278%	107%	278%	107%	415%
Operating capital as a percentage of net sales	%	177%	8%	90%	4%	122%
Cash liquidity including unused part of overdraft facilities	%	205%	51%	205%	51%	382%
Equity per share before and after dilution***	SEK	5,0	-0,2	5,0	-0,2	5,7
CASH FLOW						
Cash flow from current operations	kSEK	-66	712	-13,209	1,314	248
Cash flow from investment activities	kSEK	-1,325	0	-2,839	0	-594
Cash flow from financing activities	kSEK	1,652	-76	2,542	-346	34,242
SHARES						
Number of shares at the end of the period, before and after dilution	No.	6,333,333	50,000	6,333,333	50,000	6,333,333
Average number of shares before and after dilution***	No.	6,333,333	50,000	6,333,333	50,000	6,333,333
EMPLOYEES						
Average number of employees	No.	17	10	15	10	11
Number of employees at the end of the period	No.	19	10	19	10	13

* The order intake in foreign currency related to the interim period for 2018 and the comparative period for 2017 is converted at the average exchange rate for the respective month in 2018. The full year 2017 has been recalculated according to the average exchange rate for the whole of 2017.

** Sales growth for the period April to June 2017 and January to June 2017 is set in relation to sales for the corresponding period in 2016.

*** All periods adjusted for a new issue of shares in December 2017, a total of 6,333,333 shares.

KEY DEFINITIONS

Balance liquidity: Current assets as a percentage of short-term liabilities.

EBIT: Operational results before interest and tax.

EBITDA: Operational results before depreciation, interest and tax.

Equity per share: Equity at the end of the period divided by the adjusted number of shares at the end of the accounting period.

Sales growth: The difference in net sales between two periods, divided by net sales during the first period.

Cash liquidity: Current assets excluding inventories and including unused overdraft facilities as a percentage of short-term liabilities.

Net Debt: Gross debt, i.e. total long-term and short-term borrowing, including any used part of overdraft facilities, minus cash and cash equivalents, short-term receivables and easily realized assets.

Order intake: Value of orders received during the specified period.

Earnings per share: Earnings for the period in relation to the adjusted average number of shares during the accounting period.

Operating capital: Total current assets less short-term liabilities.

Operating margin: Operating earnings after depreciation as a percentage of net sales.

Profit margin: Earnings before taxes as a percentage of net sales.





GROUP'S CONSOLIDATED INCOME STATEMENT

SEK	Second quarter		6 months		Whole year
	2018 Apr-Jun	2017 Apr-Jun	2018 Jan-Jun	2017 Jan-Jun	2017
Net Sales	16,843,859	7,256,972	33,223,547	16,269,712	29,004,079
Other operating income*	752,260	83,389	997,913	286,071	615,914
Total operating income	17 596,119	7,340,361	34,221,460	16,555,783	29 619,993
OPERATING COSTS					
Goods	-10,045,263	-4 207,420	-20,270,920	-9,894,942	-16,984,453
Other external costs	-6,857,270	-2 524,780	-10,196,627	-5,711,195	-9,989,456
Personnel costs	-3,590,123	-906,177	-7,830,716	-1,737,131	-4,990,081
Depreciation of fixed assets	-182,897	-88,557	-343,244	-177,116	-430,658
Other operating costs*	-	-	-	-510,471	-73,335
Total operating costs	-20,675,553	-7,726,933	-38,641,507	-18,030,856	-32,467,984
Operating profit (EBIT)	-3,079,434	-386,572	-4,420,047	-1,475,073	-2,847,991
RESULTS FROM FINANCIAL ITEMS					
Other interest income and similar income items	-	47	-	47	534
Operating costs and similar income items	-43,528	-36,426	-98,243	-86,053	-202,383
Total financial items	-43,528	-36,379	-98,243	-86,006	-201,849
Earnings after financial items	-3,122,961	-422,951	-4,518,289	-1,561,079	-3,049,840
Tax on period earnings	-11,345	-141,760	-10,978	-142,709	-523
EARNINGS FOR THE YEAR	-3 134 307	-564,711	-4,529 267	-1,703 787	-3,050,363
APPLICABLE TO:					
Parent company owner	-3,134,307	-564,711	-4,529,267	-1,703,787	-3,050,363
Earnings per share applicable to parent company owner**	-0.5	-0.1	-0.7	-0.3	-0.5

* Contains exchange rate changes of operating items.

** Adjusted for a new issue of shares in December 2017, a total of 6,333,333 shares.

GROUP BALANCE SHEET

Assets

SEK	6/30/2018	6/30/2017	12/31/2017
ASSETS			
Capital assets			
Intangible capital assets			
Balanced expenses for development work and similar work	601,000	523,600	676,891
Concessions, patents, licenses, trademarks	1,361,234	1,198,303	1,326,822
Total intangible capital assets	1,962,234	1,721,903	2,003,713
Tangible capital assets			
Machinery and other technical assets	1,688,864	-	-
Inventories, tools and facilities	1,189,473	282,810	341,500
Total tangible capital assets	2,878,337	282,810	341,500
Financial assets			
Other long-term receivables	243,750	243,750	243,750
Total financial capital assets	243,750	243,750	243,750
Total capital assets	5,084,321	2,248,463	2,588,963
Current assets			
Finished goods and goods for sale	13,115,564	4,847,971	6,035,635
Total inventories, etc.	13,115,564	4,847,971	6,035,635
Short-term receivables			
Accounts receivable	8,177,186	1,419,448	3,017,940
Current tax receivables	58,633	34,829	37,939
Other receivables	1,500,487	281,744	530,337
Earned but un invoiced revenue	807,388	-	-
Prepaid costs and accrued expenses	2,341,484	477,001	2,770,436
Total short-term receivables	12,885,177	2,213,022	6,356,651
Cash and bank balances	20,648,539	1,131,996	34,059,241
Total current assets	46,649,280	8,192,989	46,451,527
TOTAL ASSETS	51,733,601	10,441,452	49,040,490

GROUP BALANCE SHEET

Equity and debt

SEK	6/30/2018	6/30/2017	12/31/2017
EQUITY*			
Total equity	31,917,187	-1,211,376	36,039,985
LONG-TERM LIABILITIES			
Liabilities to credit institutions	1,010,000	1,380,000	1,115,000
Other long-term liabilities**	2,031,921	2,650,000	700,000
Total long-term liabilities	3,041,921	4,030,000	1,815,000
SHORT-TERM LIABILITIES			
Liabilities to credit institutions	360,000	510,000	510,000
Accounts payable	12,208,248	4,069,910	6,361,257
Overdraft facilities***	1,465,061	1,757,014	-
Current tax liabilities	39,791	137,445	9,827
Other short-term liabilities	100,000	570,999	352,512
Accrued expenses and prepaid income	2,601,394	577,459	3,951,908
Total short-term liabilities	16,774,493	7,622,828	11,185,504
TOTAL EQUITY AND LIABILITIES	51,733,601	10,441,452	49,040,490

* The distribution of shareholders' equity is shown in the consolidated report on changes in shareholders' equity on the next page.

** Other long-term liabilities also include loans from owners and related parties.

*** Specification of the overdraft limit and unused part of the overdraft facility for the respective period is given below:

	6/30/2018	6/30/2017	12/31/2017
Overdraft limit (SEK)	2,300,000	2,300,000	2,300,000
Unused part of the overdraft facility (SEK)	834,939	542,986	2,300,000

GROUP'S CHANGES IN EQUITY

SEK	Share capital	Other paid-up capital	Other equity		Total equity
			Accumulated currency difference	Balanced earnings, etc.	
Opening balance 01/01/2017	50,000	1,803,000	-99,069	-1,336,887	417,044
Earnings for the year				-3,050,363	-3,050,363
Exchange rate differences when calculating foreign subsidiaries			13,643		13,643
Obtained shareholder contribution		1,900,000			1,900,000
Issue of bonus shares	450,000	-450,000			0
New issue of shares	133,333	36,626,329			36,759,662
CLOSING BALANCE 12/31/2017	633,333	39,879,329	-85,426	-4,387,250	36,039,985
Opening balance 1/1/2018	633,333	39,879,329	-85,426	-4,387,250	36,039,985
Earnings for the year				-4,529,267	-4,529,267
Exchange rate differences when calculating foreign subsidiaries			406,469		406,469
CLOSING BALANCE 6/30/2018	633,333	39,879,329	321,043	-8,916,517	31,917,187

* Liquidity for new issue of shares is offset for listing costs amounting to approximately 3.2 MSEK.

GROUP'S CASH FLOW STATEMENT

SEK	Second quarter		6 months		Whole year
	2018 Apr-Jun	2017 Apr-Jun	2018 Jan-Jun	2017 Jan-Jun	2017
ONGOING ACTIVITIES					
Operating earnings before financial items	-3,079,434	-386,572	-4,420,047	-1,475,073	-2,847,991
Adjustments for items that are not included in the cash flow					
Depreciation	182,897	88,557	343,244	177,116	430,658
Other items that are not included in the cash flow	545,381	45,268	311,076	75,368	13,643
Interest obtained	-	47	-	47	534
Interest paid	-43,528	-36,426	-98,243	-86,053	-202,383
Paid income tax	17,323	-28,826	-1,708	-45,369	-33,911
Cash flow from ongoing activities before changes in operating capital	-2,377,360	-317,952	-3,865,678	-1,353,964	-2,639,450
<i>Cash flow from changes in operating capital</i>					
Changes in inventories	-2,650,401	401,313	-7,079,929	1,221,063	33,398
Changes in operating receivables	6,910,538	1,876,456	-6,507,832	951,411	-3,189,107
Changes in operating liabilities	-1,949,072	-1,247,745	4,243,965	495,559	6,042,867
Cash flow from current operations	-66,296	712,071	-13,209,473	1,314,070	247,708
INVESTMENT ACTIVITIES					
Acquisition of intangible capital assets	-31,146	-	-147,252	-	-491,300
Acquisition of property, plant and equipment	-1,293,542	-	-2,691,350	-	-102,742
Cash flow from investment activities	-1,324,688	0	-2,838,602	0	-594,042
FINANCING ACTIVITIES					
New issue of shares	-	-	-	-	36,759,662
Change in overdraft credit	1,465,061	56,578	1,465,061	-151,102	-1,908,116
Borrowings	384,378	-	1,466,535	-	3,500,000
Amortization of loans	-197,510	-132,500	-389,615	-195,000	-4,110,000
Cash flow from financing activities	1,651,929	-75,922	2,541,981	-346,102	34,241,546
CASH FLOW FOR THE PERIOD					
Liquid capital at the beginning of the period	20,292,201	495,846	34,059,241	164,028	164,028
Exchange rate difference in cash	95,393	-	95,393	-	-
LIQUID CAPITAL AT THE END OF THE PERIOD	20,648,539	1,131,996	20,648,539	1,131,996	34,059,241

PARENT COMPANY'S CONSOLIDATED INCOME STATEMENT

SEK	Second quarter		6 months		Whole year
	2018 Apr-Jun	2017 Apr-Jun	2018 Jan-Jun	2017 Jan-Jun	2017
Net Sales	147,672	-	304,175	-	127,373
Other operating income	506,229	-	515,850	-	-
Total operating income	653,901	0	820,025	0	127,373
OPERATING COSTS					
Other external costs	-302,659	-	-626,201	-	-192,310
Other operating costs	-	-	-	-	-17,928
Total operating costs	-302,659	0	-626,201	0	-210,238
Operating profit (EBIT)	351,242	0	193,824	0	-82,865
RESULTS FROM FINANCIAL ITEMS					
Other interest income and similar income items	77,181	-	154,362	-	4,225
Operating costs and similar income items	-	-	-	-	-2,250
Total financial items	77,181	0	154,362	0	1,976
Earnings after financial items	428,423	0	348,186	0	-80,889
Tax on period earnings	-	-	-	-	-
EARNINGS FOR THE YEAR	428,423	0	348,186	0	-80,889

PARENT COMPANY'S BALANCE SHEET

SEK	6/30/2018	6/30/2017	12/31/2017
ASSETS			
Capital assets			
Financial assets			
Shares in Group companies	8,835,194	1,816,072	8,585,805
Receivables from Group companies	22,053,586	-	14,517,359
Total financial capital assets	30,888,780	1,816,072	23,103,164
Total capital assets	30,888,780	1,816,072	23,103,164
Current assets			
Short-term receivables			
Receivables from Group companies	952,063	-	143,295
Other receivables	282,981	-	217,580
Prepaid costs and accrued expenses	58,146	-	4,225
Total short-term receivables	1,293,189	0	365,100
Cash and bank balances	8,695,207	302	19,924,944
Total current assets	9,988,396	302	20,290,044
TOTAL ASSETS	40,877,176	1,816,374	43,393,208
EQUITY			
Total equity	40,617,262	1,690,302	40,269,075
LONG-TERM LIABILITIES			
Liabilities to Group companies	-	126,072	-
Total long-term liabilities	0	126,072	0
SHORT-TERM LIABILITIES			
Accounts payable	36,000	-	631,258
Accrued expenses and prepaid income	223,915	-	2,492,875
Total short-term liabilities	259,915	0	3,124,134
TOTAL EQUITY AND LIABILITIES	40,877,176	1,816,374	43,393,208

FINANCIAL CALENDAR

FlexQubes financial reports are available on the company's website. The following reports are scheduled to be published as follows:

- Quarterly report 3, 2018 10/31/2018
- Quarterly report 4, 2018 2/15/2019



CONTACT INFORMATION

FlexQube AB (publ)
556905-3944
Kungsgatan 28
411 19 Göteborg, Sweden

Investor Relations
ir@flexqube.com
+4672-711-1477
www.flexqube.com



www.flexqube.com
#flexqube
www.twitter.com/flexqube
www.linkedin.com/company/flexqube-ab/
www.youtube.com/user/FlexQube
www.facebook.com/FlexQube
www.instagram.com/flexqube/